

NO	MMA 01 073 100	REV	4	DATE	2017/03/21
----	----------------	-----	---	------	------------

SENSOR ABM

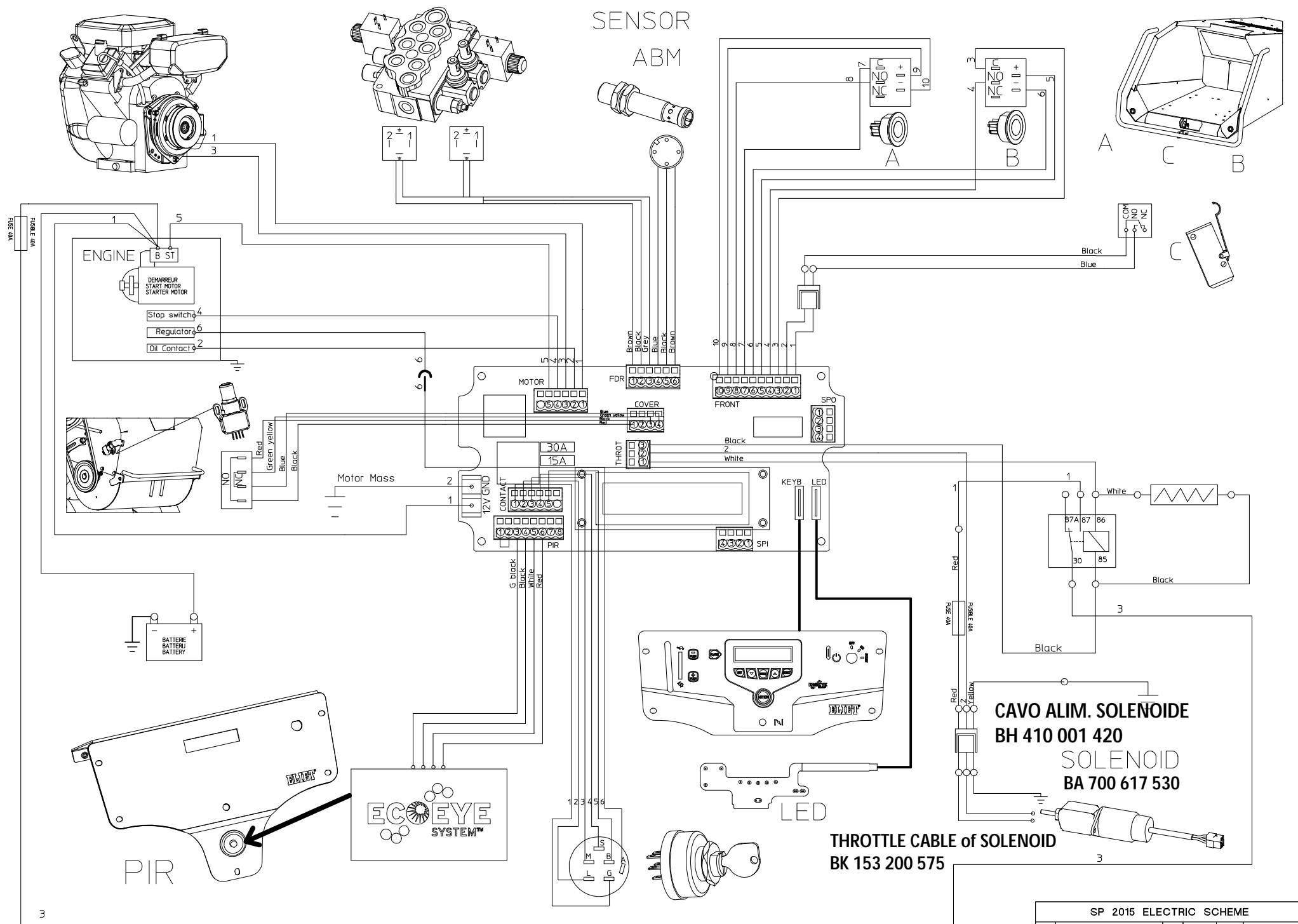

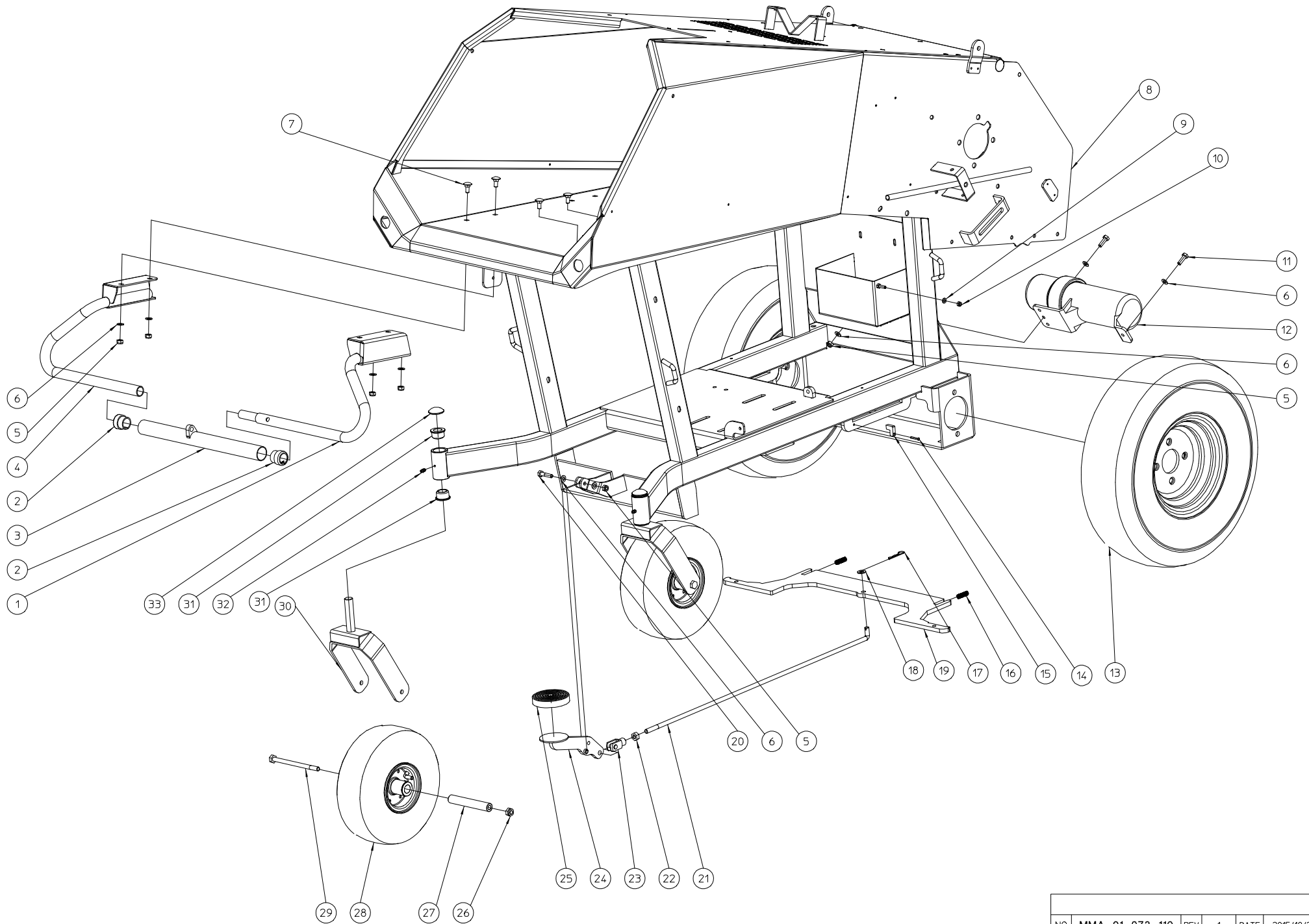

NO	MMA 01 073 110	REV	1	DATE	2015/10/27
----	----------------	-----	---	------	------------

#	Order nr	article description	quantity
1	MPA 01 073 410	steer right	1
2	BR 910 000 010	nylon bushing with collar (25/30/34x30/15)	2
3	MPA 01 073 430	command tube	1
4	MPA 01 073 420	steer left	1
5	BS 502 000 800	self locking nut m8 din 985	7
6	BS 531 000 800	washer m8 din 125	10
7	BS 554 100 820	bolt m8x20 din 603	4
8	MPA 01 073 100	chassis	1
9	BS 531 000 600	washer m6 din 125	1
10	BS 502 000 600	self locking nut m6 din 985	1
11	BS 512 000 825	bolt m8x25 din 933	2
12	BQ 790 010 020	document holder 320 mm	1
13	BW 054 060 000	rear wheel 6,00-9 6pr	2
14	BB 221 004 250	pop plug steel 3.9x25 din 7337 a	2
15	BR 910 000 050	nylon touch block	2
16	BV 907 000 020	spring 10x1x60	2
17	BB 040 102 040	hairpin cotter 2mm din 11024	1
18	BS 531 001 000	washer m10 din 125	1
19	MPA 01 073 540	brake plate	1
20	BS 511 000 835	bolt m8x35 din 931	1
21	MPA 01 073 220	brake rod	1
22	BS 501 001 000	nut m10 din 934	1
23	BS 556 001 000	fork m10x20 din 71752	1
24	MPA 01 070 130	brake pedal	1
25	BR 900 000 110	rubber socks dia 90x18mm	1
26	BS 502 001 000	self locking nut m10 din 985	2
27	MPA 01 070 390	front wheel axle	2
28	BW 029 020 100	front wheel 4.00-4	2
29	BS 511 001 055	bolt m10x150 din 931	2
30	MPA 01 073 210	wheel fork	2
31	BR 112 201 910	nylon bushing with collar (20.5/30/35x19/2.5)	4
32	BY 100 106 100	grease fitting m6 din 71412	2
33	BB 011 000 200	starlock 20mm	2

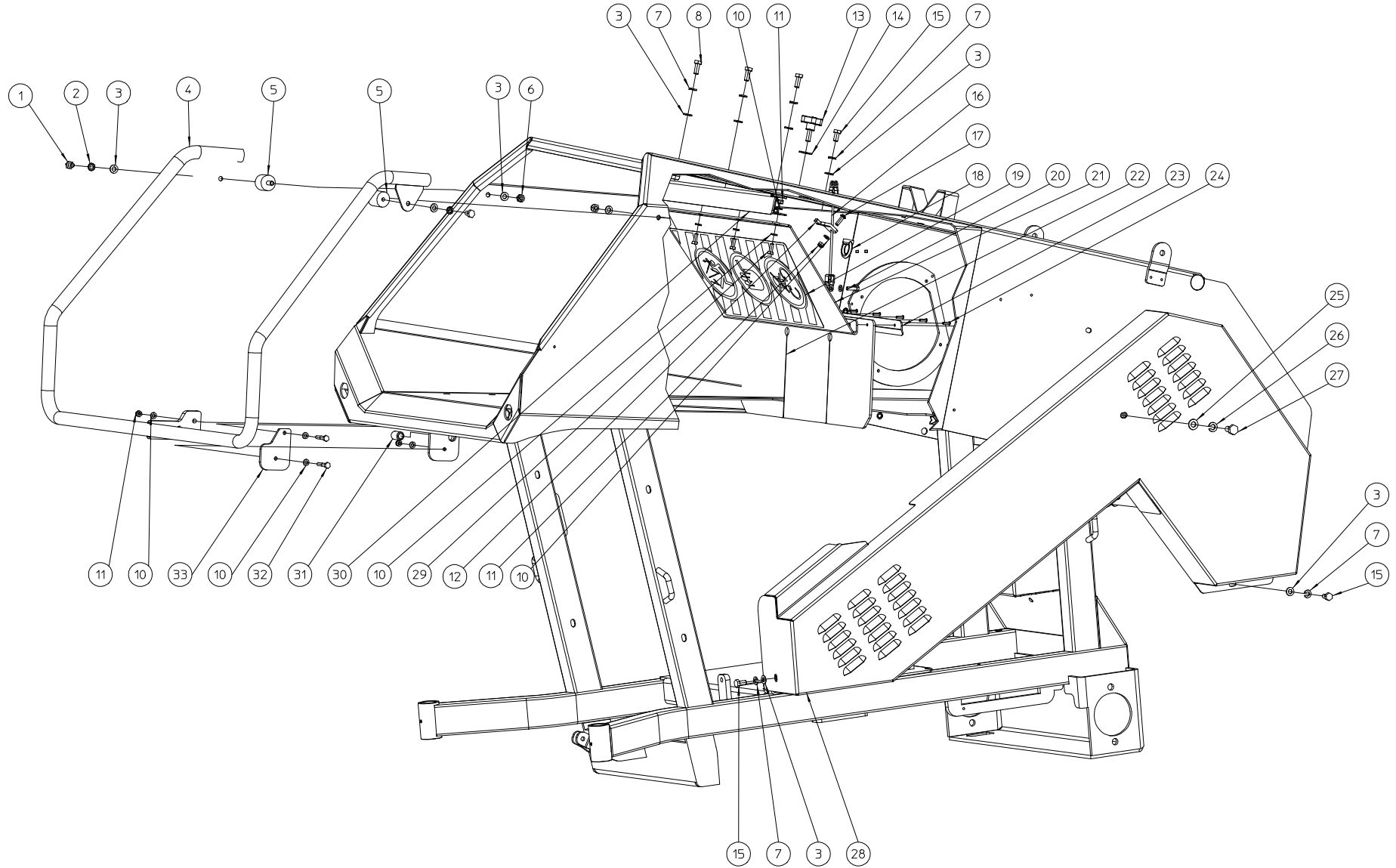

NO	MMA 01 073 120	REV	1	DATE	2015/10/28
----	----------------	-----	---	------	------------

#	Order nr	article description	quantity
1	BS 512 000 812	bolt m8x12 din 933	2
2	BS 534 000 800	lock washer m8 din 6798a	2
3	BS 531 000 800	washer m8 din 125	10
4	MPA 01 073 180	safety handle	1
5	BR 600 130 301	antivibration blocks 30x30b m8x16	2
6	BS 502 000 800	self locking nut m8 din 985	2
7	BS 533 000 800	lock washer m8 din 127b	6
8	BS 512 000 820	bolt m8x20 din 933	3
10	BS 531 000 600	washer m6 din 125	15
11	BS 502 000 600	self locking nut m6 din 985	8
12	MPA 01 073 810	connection flap control	1
13	BN 630 208 200	lob knob m8x20	1
14	BS 532 008 253	washer m8x25x1.5	1
15	BS 512 000 816	bolt m8x16 din 933	3
16	BK 152 250 201	cable support anti projectionplate	1
17	BS 522 500 620	screw m6x20 iso 7380	1
18	BS 507 000 008	lifting eye nut m8 din 582	1
19	BQ 505 010 100	safety sticker 465x200 (shield)	1
20	BS 512 000 620	bolt m6x20 din 933	1
21	MPA 01 073 510	anti projectionplate	1
22	BR 900 001 670	rubber anti projection flap 510 x 210	1
23	MPA 01 073 590	support rubber anti-projection	1
24	BB 221 104 140	pop plug alu 3.9x14 din 7337 a	6
25	BS 531 001 000	washer m10 din 125	1
26	BS 533 001 000	lock washer m10 din 127b	1
27	BS 512 001 020	bolt m10x20 din 933	1
28	MPA 01 073 200	belt cover	1
29	BS 512 000 616	bolt m6x16 din 933	4
30	MPA 01 073 300	set square support anti-projection	1
31	BS 351 601 624	spring loaded plunjer m16x24	1
32	BS 511 000 635	bolt m6x35 din 931	2
33	MPA 01 073 650	plate security switch	1

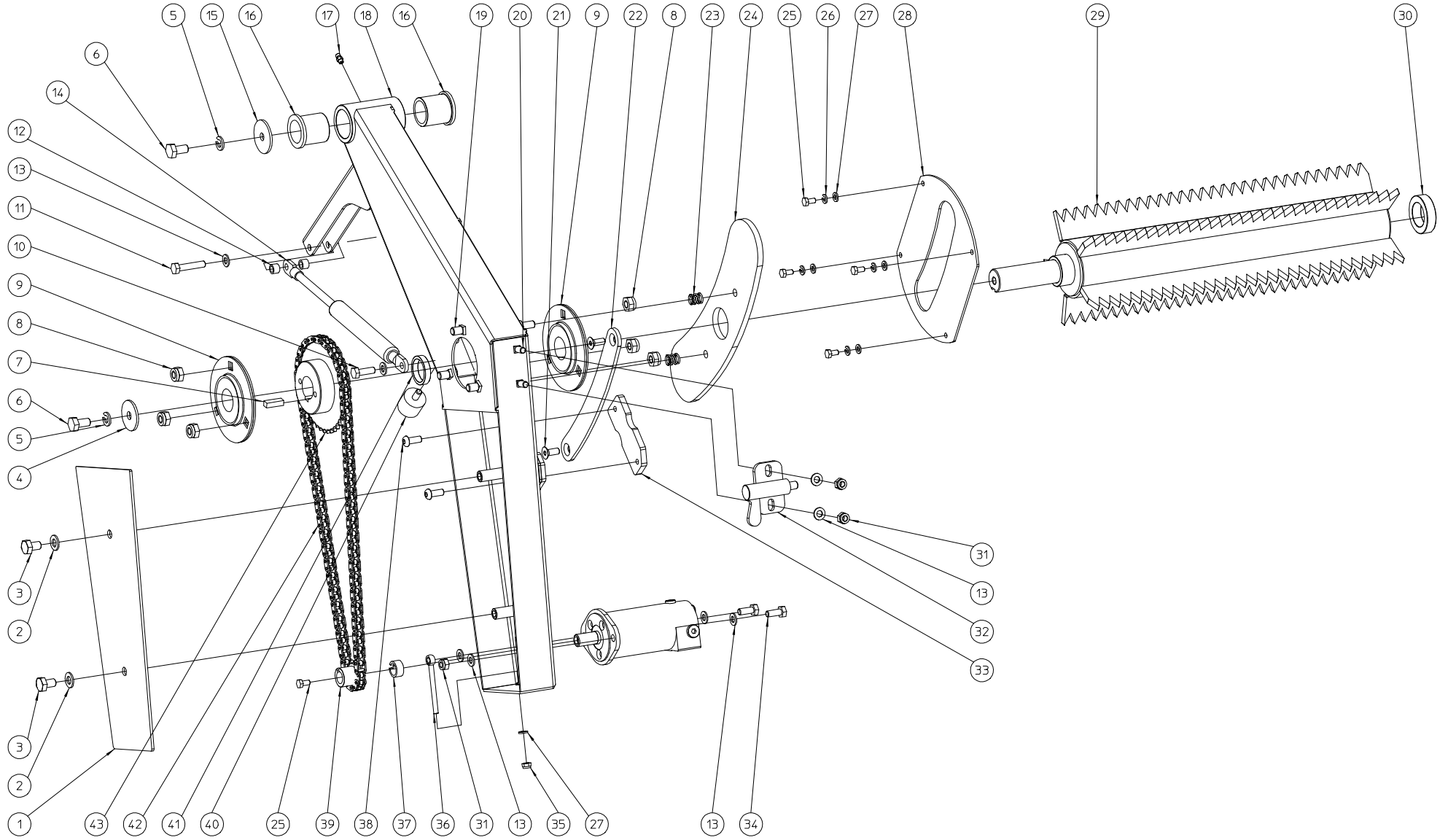

NO	MMA 01 073 130	REV	2	DATE	2016/02/23
----	----------------	-----	---	------	------------

#	Order nr	article description	quantity
1	MPA 01 073 550		1
2	BS 531 001 000	washer m10 din 125	2
3	BS 512 001 016	bolt m10x16 din 933	2
4	BS 532 010 406	washer m10x40x3	1
5	BS 533 001 000	lock washer m10 din 127b	2
6	BS 512 001 020	bolt m10x20 din 933	2
7	BB 341 080 725	key 8x7x25 din 6880	1
8	BS 502 001 000	self locking nut m10 din 985	6
9	BL 801 503 000	bearing + flanges aspf 206	2
10	BS 512 000 825	bolt m8x25 din 933	1
11	BS 512 000 840	bolt m8x40 din 933	1
12	BS 531 000 800	washer m8 din 125	9
13	MPA 01 070 420	bushing	2
14	BV 521 010 001	gas struts 500n x 100mm	1
15	MPA 01 073 870	washer 44x10x3	1
16	BR 112 304 090	nylon bushing with collar	2
17	BY 100 106 100	grease fitting m6 din 71412	1
18	MPA 01 073 130	arm pinch roll	1
19	BS 554 101 020	bolt m10x20 din603	6
20	BS 554 100 820	bolt m8x20 din 603	2
21	BS 522 100 820	screw m8x20 din 7991	2
22	MPA 01 073 790	guide arm feed roller	1
23	BV 911 000 010	spring 14x2x16	2
24	BR 910 000 810	nylon cover sp2015	1
25	BS 512 000 612	bolt m6x12 din 933	5
26	BS 533 000 600	lock washer m6 din 127b	4
27	BS 531 000 600	washer m6 din 125	5
28	MPA 01 073 560		1
29	MPA 01 073 110	pinch roll	1
30	BR 111 321 310	nylon bushing (32/50x13)	1
31	BS 502 000 800	self locking nut m8 din 985	4
32	MPA 01 073 290	lock 10mm	1
33	MPA 01 073 780	thrust block arm feed roller	1
34	BS 512 000 820	bolt m8x20 din 933	2
35	BS 502 000 600	self locking nut m6 din 985	1
36	BS 551 100 646	eye bolt m6x70 din 444	1
37	MPA 01 070 430	spacer ring	1
38	BS 522 500 820	screw m8x20 iso 7380	2
39	BA 161 012 162	sprocket simplex 3/8"x7/32" 12t	1
40	BA 151 400 000	connecting chain link simplex (1/2) 3/8"x7/32"	1
41	BA 151 200 000	connecting chain link simplex 3/8"x7/32"	1
42	BA 101 104 020	chain simplex 3/8"x7/32" 104l	1
43	BR 600 530 250		1
44	MPA 01 073 680	spacer ring	1
45	BA 161 040 301	sprocket 40z 3/8"x7/32" simplex	1

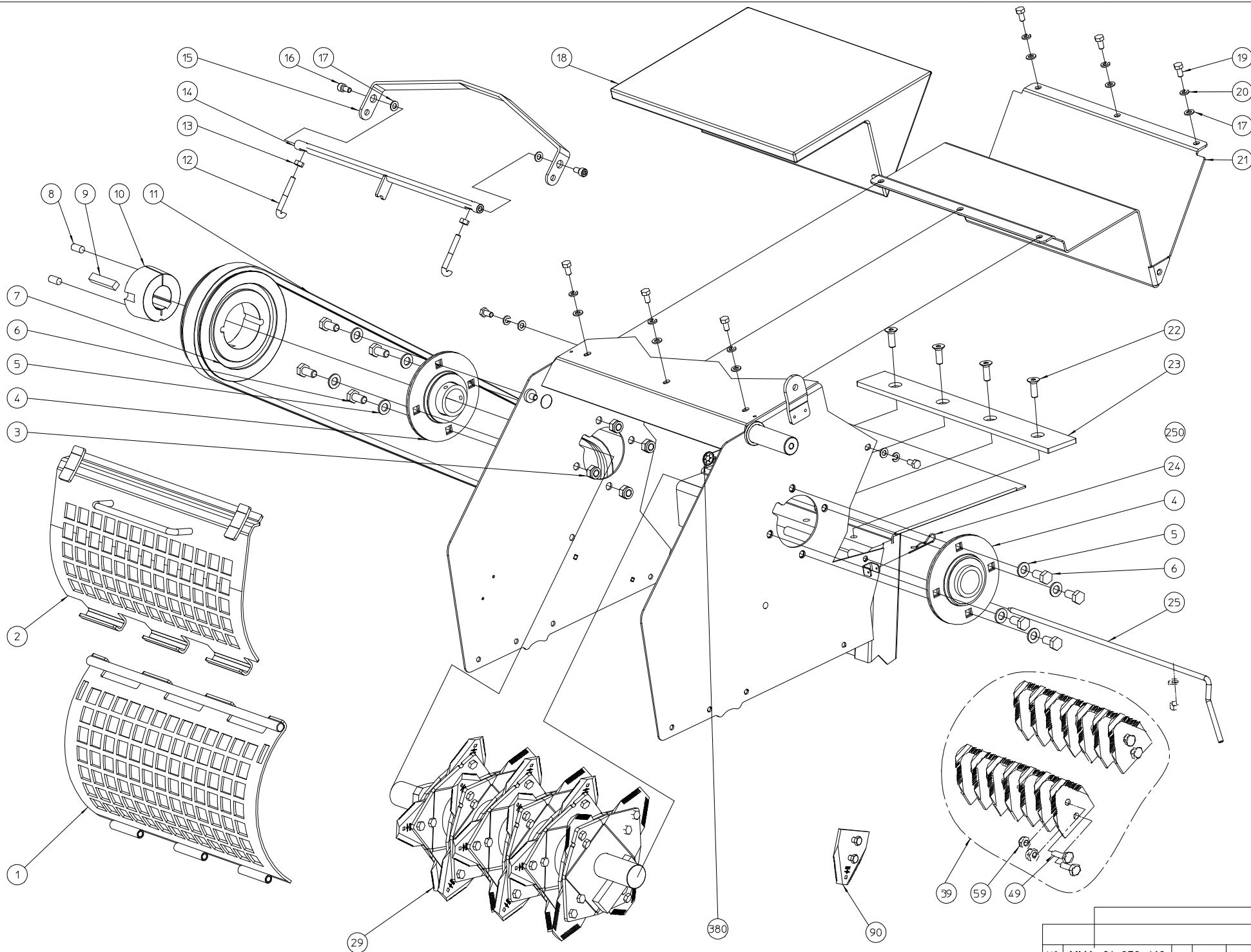

#	Order nr	article description	quantity
1	MPA 01 073 150	lower calibrating grill	1
2	MPA 01 073 160	upper calibrating grill	1
3	BS 502 001 200	self locking nut m12 din 985	8
4	BL 801 604 001	kit bearing ucpf 208 complete	2
5	BS 531 001 200	washer m12 din 125	8
6	BS 512 001 225	bolt m12x25 din 933	8
7	BA 562 718 030	pulley 3 spa 180 tl2517	1
8	BB 501 311 220	set screw 7/16"x7/8"	2
9	BB 341 121 060	key 12x10x60 din 6880	1
10	BB 501 164 000	taper lock tl 2517-40	1
11	BA 552 221 200	xpa 2120/2 powerband multibrins	1
12	MPA 01 070 400	hook for rapid fastener	2
13	BS 501 000 800	nut m8 din 934	2
14	MPA 01 073 380	axe closure grate	1
15	MPA 01 073 570	lever closure grate	1
16	BS 521 100 816	screw m8x16 din 912	2
17	BS 531 000 800	washer m8 din 125	10
18	BQ 158 010 150	isolation rotor	1
19	BS 512 000 816	bolt m8x16 din 933	8
20	BS 533 000 800	lock washer m8 din 127b	8
21	MPA 01 073 310	isolationplate	1
22	BS 022 101 030	bolt m8x18 din 7991 10,9	4
23	MPA 01 070 180	fixation profile	1
24	BB 040 102 040	hairpin cotter 2mm din 11024	1
25	MPA 01 070 210	axle grating	1
29		Rotor assembly Superprof 2015	1
29	MPA 01 280 080	Rotor assembly Superprof Max 2015	1
39	BU 401 300 202	standard - 8 set steel knife Superprof	1
39	BU 401 301 000	resist -10 set steel knife Superprof MAX	1
49	BS 011 300 827	bolt 8 standard steel knife Superprof	48
49	BS 012 401 030	bolt 10 resist steel knife Superprof MAX	48
59	BS 502 000 811	nut 8 standard steel knife Superprof	48
59	BS 502 001 011	nut 10 resist steel knife Superprof MAX	48
90	BU 101 300 800	standard - 8 steel knife	24
90	BU 101 301 000	resist - 10 steel knife Superprof MAX	24
250	BS 531 001 000	washer m10 din 125	48
380	BB 011 000 090	starlock 9mm	1

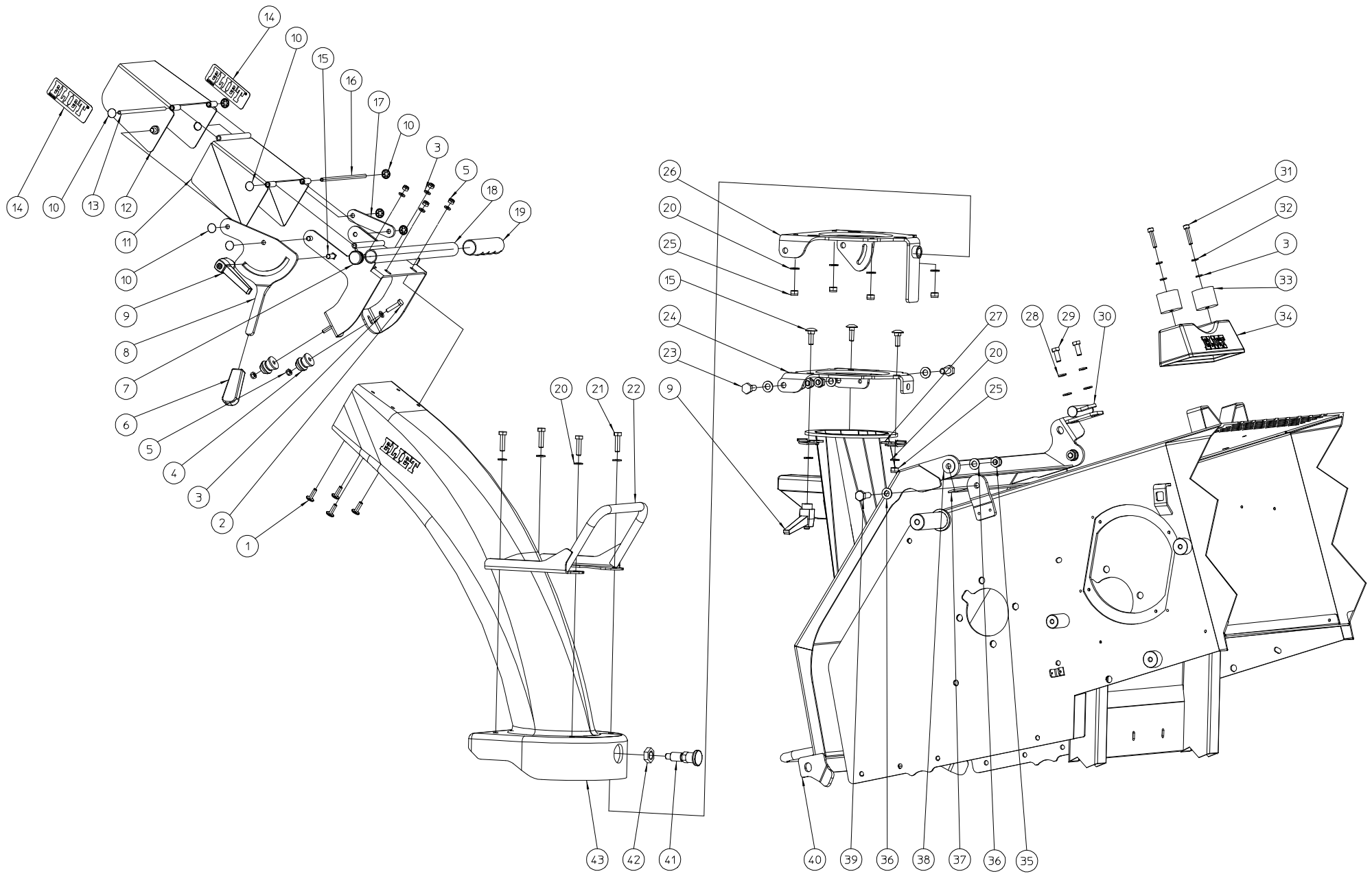

NO	MMA 01 073 150	REV	2	DATE	2016/02/11
----	----------------	-----	---	------	------------

#	Order nr	article description	quantity
1	BS 552 100 620	screw m12x40 type kf	4
2	BS 512 000 630	bolt m6x30 din 933	2
3	BS 531 000 600	washer m6 din 125	8
4	BO 530 600 001	hook	2
5	BS 502 000 600	self locking nut m6 din 985	6
6	BN 230 100 202	plastic handgripp 15x5x6 pvc	1
7	BR 020 501 250	tube cap Ø 25mm	1
8	MPA 01 073 610	lever flap control	1
9	BN 530 108 800	clamp levers	2
10	BB 011 000 080	starlock 8mm	8
11	MPA 01 073 270	flap ejection	1
12	MPA 01 310 540	directional valves blow chute low	1
13	MPA 01 311 080	axle valve - up	1
14	BQ 501 010 090	sticker eliet 100x35	2
15	BS 554 100 825	bolt m8x25 din 603	4
16	MPA 01 311 090	axle valve - down	1
17	MPA 01 073 600	rod flap ejection	1
18	MPA 01 073 260	support flap ejection	1
19	BN 230 100 408	plastic grip 1"	1
20	BS 531 000 800	washer m8 din 125	13
21	BS 512 000 830	bolt m8x30 din 933	4
22	MPA 01 073 280	handle ejection	1
23	BS 512 001 025	bolt m10x25 din 933	2
24	MPA 01 074 360		1
25	BS 502 000 800	self locking nut m8 din 985	6
26	MPA 01 074 370		1
27	MPA 01 073 520	tube connection	3
28	BS 533 000 800	lock washer m8 din 127b	2
29	BS 512 000 820	bolt m8x20 din 933	2
30	MPA 01 073 290	lock 10mm	1
31	BS 521 100 630	screw m6x30 din 912	2
32	BS 533 000 600	lock washer m6 din 127b	2
33	BO 530 600 002	socket	2
34	BR 930 070 020	support discharge tunnel	1
35	BS 502 001 000	self locking nut m10 din 985	4
36	BS 531 001 000	washer m10 din 125	8
37	BR 001 512 031	epdm cellular rubber adhesive 3 x 12 x 480 mm	1
38	BR 112 100 600	nylon bushing with collar (10/13.5/25x6/2.5)	2
39	BS 512 001 030	bolt m10x30 din 933	2
40	MPA 01 073 250	rear	1
41	BN 000 216 580		1
42	BS 501 901 601		1
43	BR 930 070 010	discharge tunnel	1

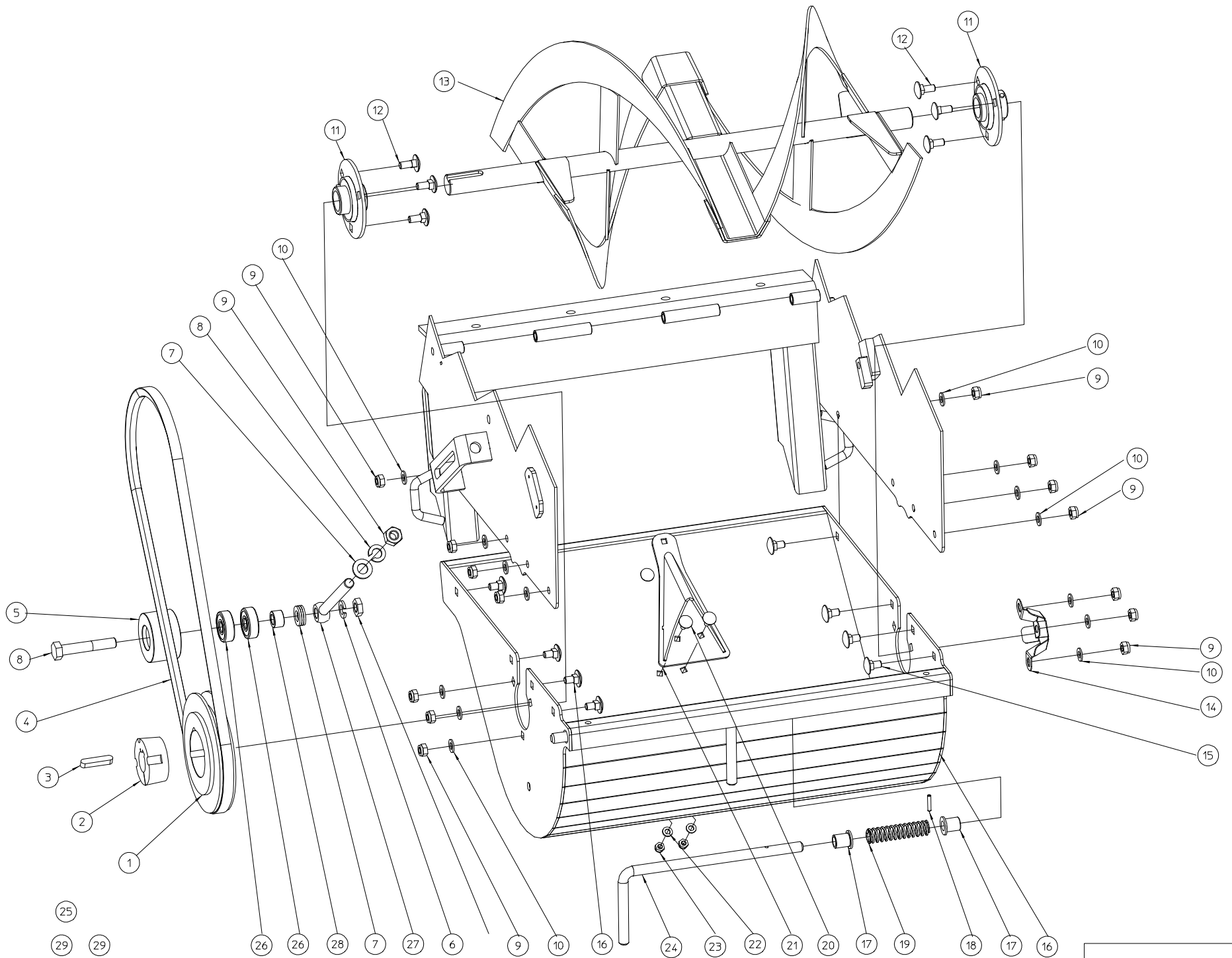

NO	MMA 01 073 160	REV	2	DATE	2016/10/24
----	----------------	-----	---	------	------------

#	Order nr	article description	quantity
1	BA 562 714 001	pulley spa 140x25x8	1
2	BB 501 132 500	taper lock tl 1610-25	1
3	BB 351 080 760	key 8x7x60 din 6885a	1
4	BA 521 212 070	xpa 1207 quad-power iii	1
5	BA 599 006 101	idler roller Ø60	1
6	BS 531 001 200	washer m12 din 125	1
7	BS 533 001 200	lock washer m12 din 127b	1
8	BS 511 001 247		1
9	BS 502 000 800	self locking nut m8 din 985	15
10	BS 531 000 800	washer m8 din 125	15
11	BL 801 502 502	bearing + flanges ucpf 205	2
12	BS 554 100 820	bolt m8x20 din 603	6
13	MPA 01 073 320	coclea	1
14	MPA 01 041 260	bearing protection cover pf205 + shaft	1
15	BS 554 100 816	bolt m8x16 din 603	8
16	MPA 01 073 170	ejection tray	1
17	BR 112 201 290	nylon bushing with collar (12x16x20)	4
18	BB 120 040 200	locking 4x20 din 1481	2
19	BV 907 000 030		2
20	BS 554 100 616	bolt m6x16 din 603	3
21	MPA 01 073 700		1
22	BS 531 000 600	washer m6 din 125	3
23	BS 502 000 600	self locking nut m6 din 985	3
24	MPA 01 073 670		2
25	MPA 01 074 470		1
26	BL 001 203 703	bearing 6301 2rz	2
27	MPA 01 074 480		1
28	MPA 01 330 810	spacer tightener pulley	1

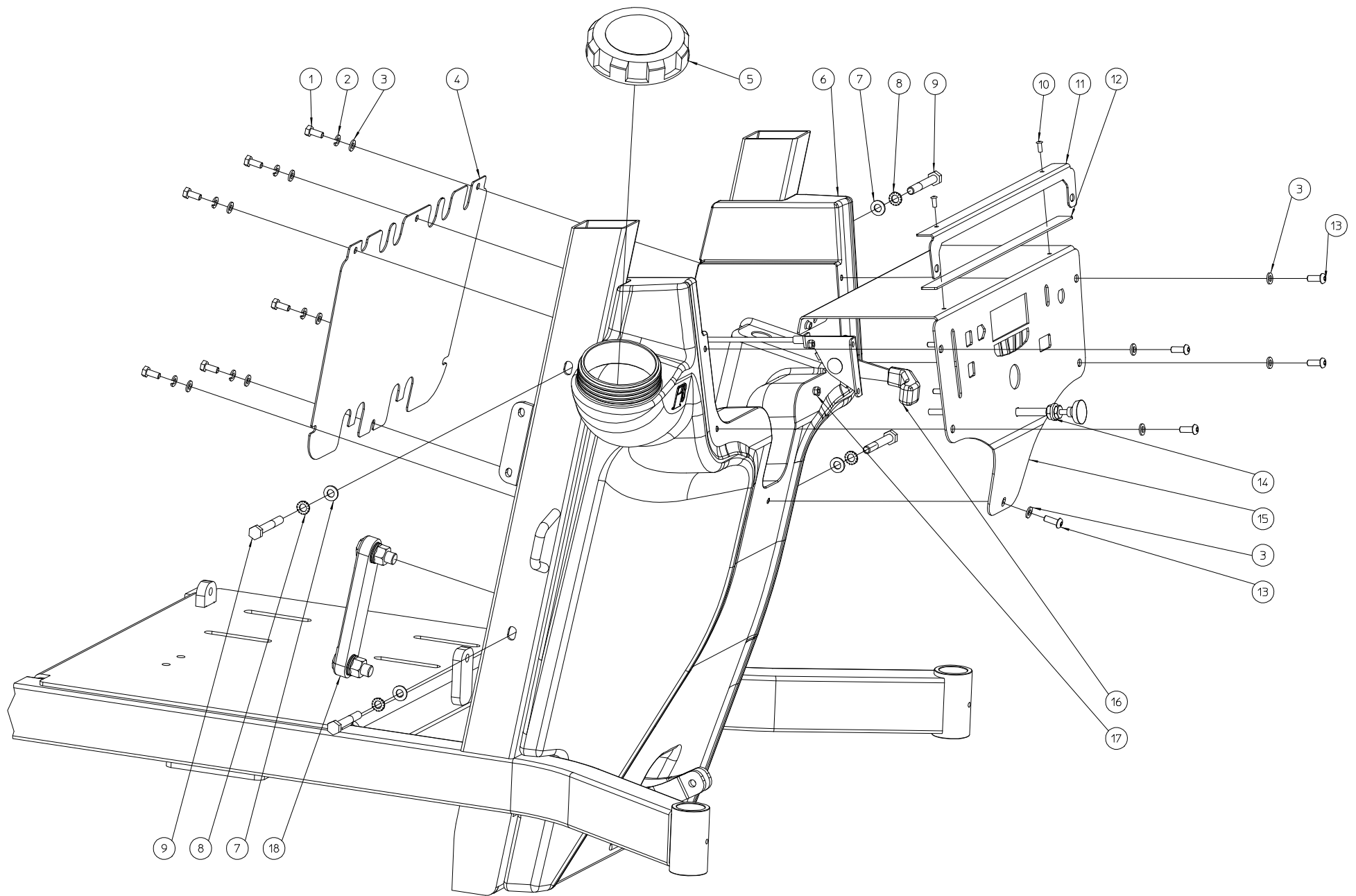

#	Order nr	article description	quantity
1	BS 512 000 614	bolt m6x14 din 933	6
2	BS 533 000 600	lock washer m6 din 127b	6
3	BS 531 000 600	washer m6 din 125	11
4	MPA 01 073 800	closure control panel	1
5	BH 720 505 885	cap for tank	1
6	BY 717 212 020	plastic tank zwart 20l	1
7	BS 531 000 800	washer m8 din 125	4
8	BS 534 000 800	lock washer m8 din 6798a	4
9	BS 511 000 844	bolt m8x60 din 931	4
10	BB 221 104 100	pop plug alu 3.9x10 din 7337 a	2
11	MPA 01 073 880	set square control panel	1
12	BR 900 001 700	extern isolation	1
13	BS 522 500 616	screw m6x16 iso 7380	5
14	BK 181 151 060	choke control	1
15	MPA 01 073 370	control panel	1
16	BK 164 310 900	throttle control + cable	1
17	BS 502 000 500	self locking nut m5 din 985	2
18	BH 730 404 005	level gauge 127 mm	1

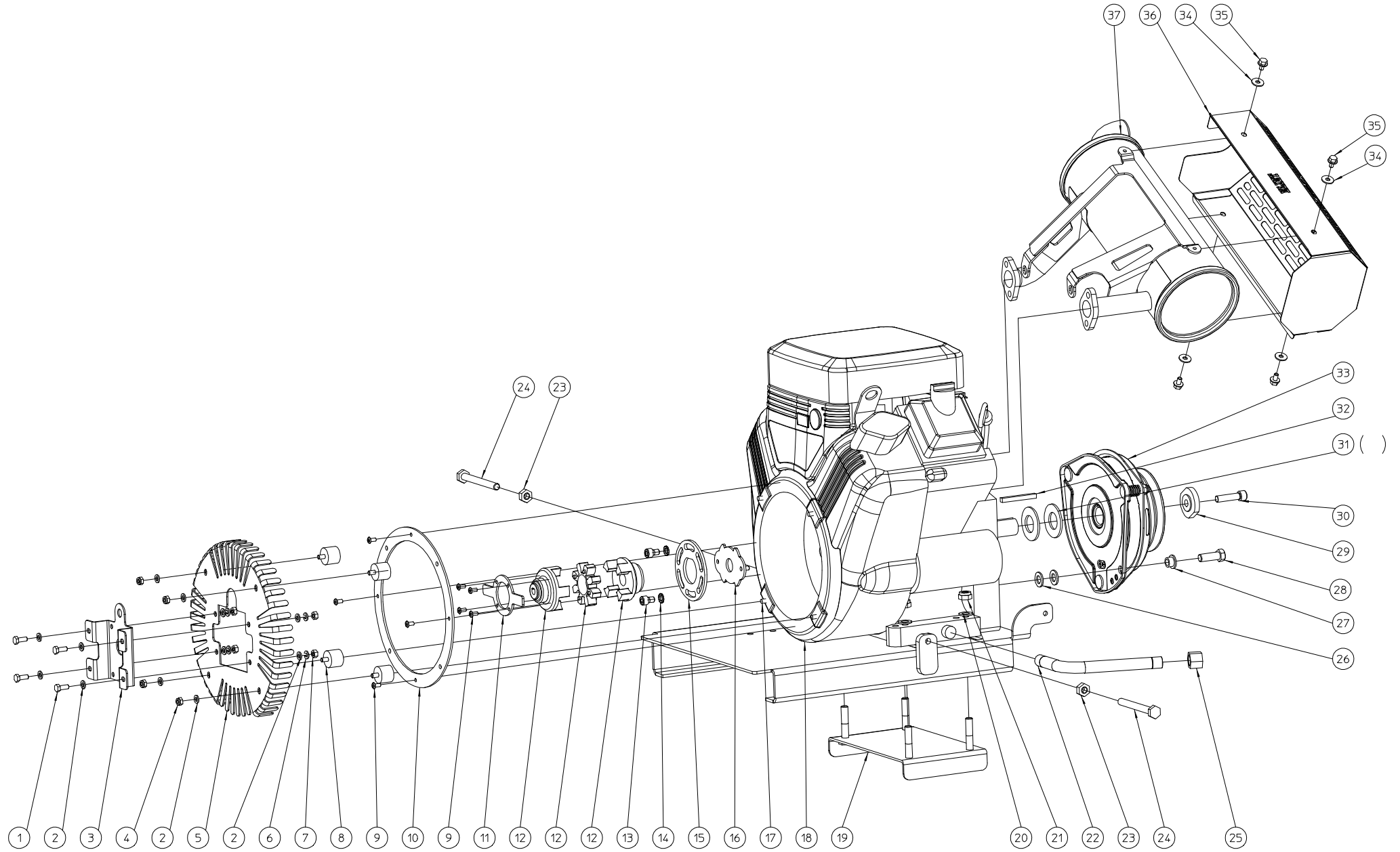

SP 2015 -- ENGINE						
NO	MMA 01 073 180	REV	3	DATE	2016/11/23	

#	Order nr	article description	quantity
1	BS 512 000 616	bolt m6x16 din 933	4
2	BS 531 000 600	washer m6 din 125	12
3	MPA 01 073 820		1
4	BS 502 000 600	self locking nut m6 din 985	4
5	MPA 01 073 390		1
6	BS 533 000 600	lock washer m6 din 127b	4
7	BS 501 000 600	nut m6 din 934	4
8	BR 600 225 201	antivibration blocks 25x20b m6x10	4
9	BB 221 005 100	pop plug steel 4.8x10 din 7337 a	8
10	MPA 01 070 670	engine housing reinforcement	1
11	MPA 01 073 720	rotation measuring point	1
12	BA 201 210 100	elastic coupling m20x1.5	1
13	BS 521 100 812	screw m8x12 din 912	2
14	BS 534 000 800	lock washer m8 din 6798a	2
15	MPA 01 070 680	connecting disk for elastic coupling	1
16	MPA 01 070 690	centring coupling	1
17	MPA 01 071 050	support reinforcement ring	4
18	BM 201 318 001	b&s vanguard twin 18 hp	1
19	MPA 01 070 230	engine fixing plate	1
20	BS 531 001 000	washer m10 din 125	4
21	BS 502 001 000	self locking nut m10 din 985	4
22	BM 261 300 400	draining pipe	1
23	BS 501 001 000	nut m10 din 934	2
24	BS 512 001 050	bolt m10x100 din 933	2
25	BT 174 150 600	terminal nut 3/8"	1
27	BR 112 101 011	nylon bushing with collar (10/14/20x7/16")	1
28	BS 512 951 132	hexagon bolt galvanised 7/16 x 1" 1/4 unc	1
29	MPA 01 074 380	ring clutch SP2015	1
30	BS 521 441 040	screw unf 3/8x1.1/2" din 912	1
31	BS 033 525 501		2
32	BB 342 060 657	key 6.35x6.35x57 din 6880	1
33	BA 250 104 010	electrical coupling spa 118 ii	1
34	BS 532 006 183	washer m6x18x1.5	4
35	BS 511 400 610	hexagon flange bolts m6x10 din 6921	4
36	MPA 01 073 450	muffler protection	1
37	BM 261 300 730	muffler engine	1
47	MPA 01 074 460	support propeller drive	1
57	MPA 01 074 440	spacer ring tension engine	2
67	BS 531 000 800	washer m8 din 125	1
77	BS 533 000 800	lock washer m8 din 127b	1
87	BS 512 000 816	bolt m8x16 din 933	1
97	MPA 01 074 450	spacer ring sp2015	1
107	BM 260 691 613	gasket b&s	2

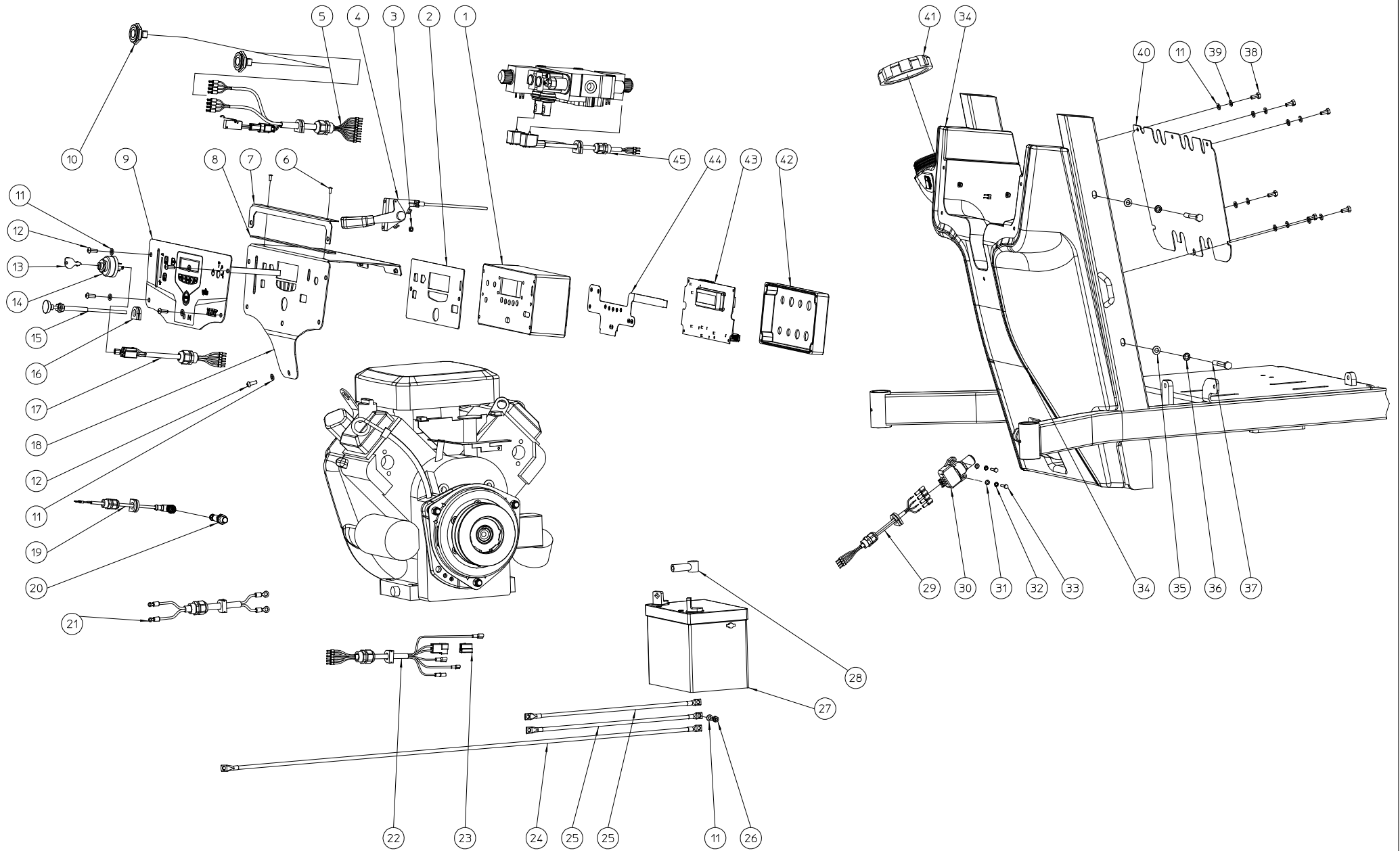

#	Order nr	article description	quantity
1	BE 142 412 101	electrical bay	1
2	BR 900 001 690	isolation electrical bay	1
3	BS 502 000 500	self locking nut m5 din 985	4
4	BK 164 310 900	throttle control + cable	1
5	BE 099 000 606	cable control buttons	1
6	BB 221 104 100	pop plug alu 3.9x10 din 7337 a	2
7	MPA 01 073 880	set square control panel	1
8	BR 900 001 700	extern isolation	1
9	BE 700 021 000	control panel	1
10	BE 120 081 420	control button	2
11	BS 531 000 600	washer m6 din 125	12
12	BS 522 500 616	screw m6x16 iso 7380	5
13	BM 260 691 959	ignition key	1
14	BM 260 692 318	ignition switch	1
15	BK 181 151 060	choke control	1
16	BR 000 213 521	rubber grommets	1
17	BE 099 000 602	cable ignition switch	1
18	MPA 01 073 370	control panel	1
19	BE 099 000 607	cable sensor	1
20	BE 400 010 200	sensor	1
21	BE 099 000 609	cable power requirement	1
22	BE 099 000 601	engine cable	1
23	BE 032 180 907	housing	1
24	BE 090 281 031	red wire 16mm ² - 1030mm	1
25	BE 090 180 371	black wire 16mm ² - 370mm	2
26	BS 502 000 600	self locking nut m6 din 985	1
27	BE 240 120 300	battery 12v 30ah	1
28	BR 701 010 150	terminal cover	1
29	BE 099 000 605	cable rear safety interlock	1
30	BE 120 030 020	safety switch	1
31	BS 531 000 400	washer m4 din 125	2
32	BS 534 000 400	lock washer m4 din 6798a	2
33	BS 512 000 420	bolt m4x20 din 933	2
34	BY 717 212 020	plastic tank zwart 20l	1
35	BS 531 000 800	washer m8 din 125	4
36	BS 534 000 800	lock washer m8 din 6798a	4
37	BS 511 000 844	bolt m8x60 din 931	4
38	BS 512 000 614	bolt m6x14 din 933	6
39	BS 533 000 600	lock washer m6 din 127b	6
40	MPA 01 073 800	closure control panel	1
41	BH 720 505 885	cap for tank	1
42	BE 142 412 102	cover electrical bay	1
43	BE 700 023 000	pcb sp2015	1
44	BE 700 022 000	led print	1
45	BE 099 000 604	cable solenoid valve	1

SUPERPROF 2015 - 2017

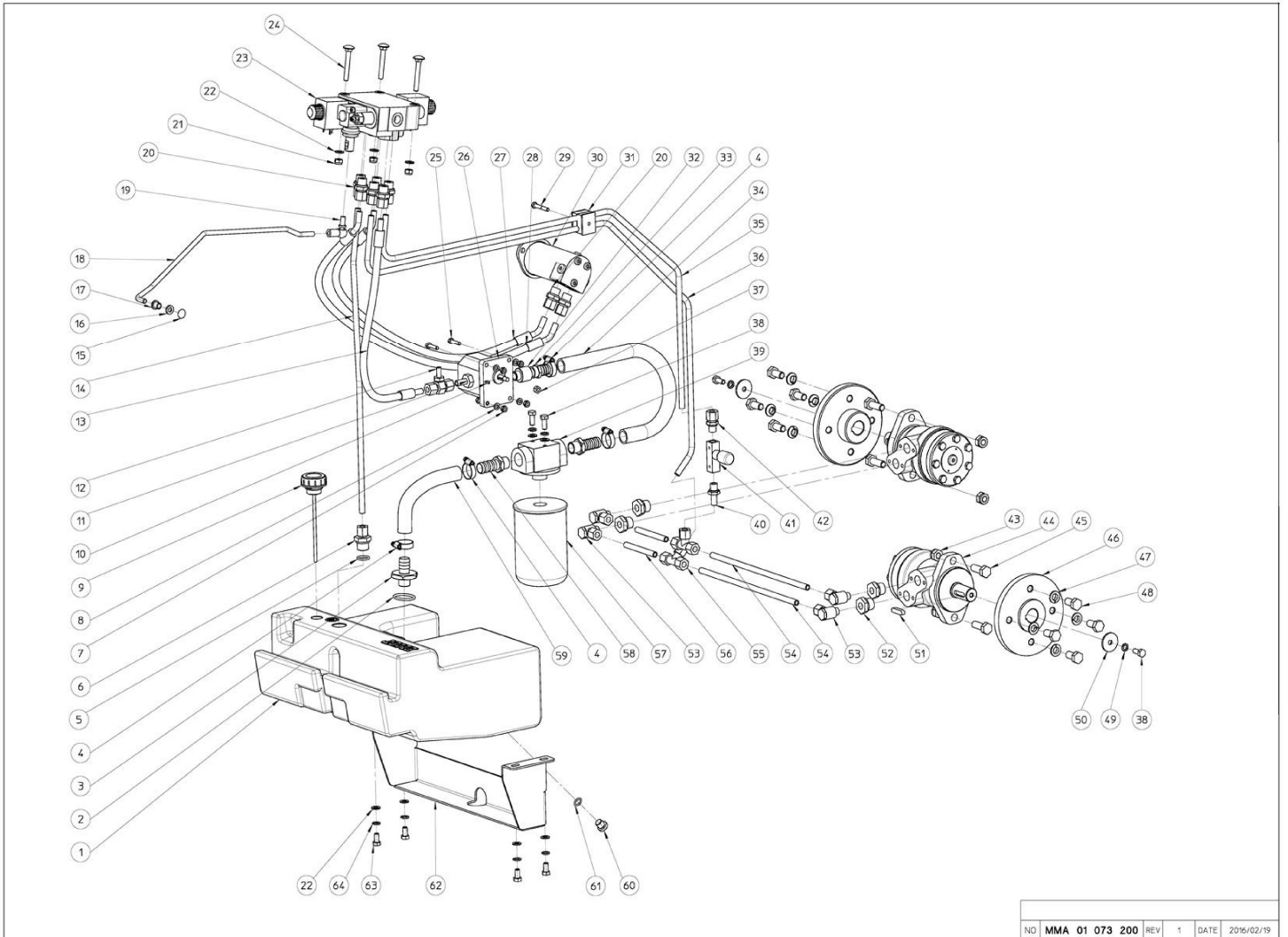

NO	MMA 01 073 200	REV	1	DATE	2016/02/19
----	----------------	-----	---	------	------------

#	Order nr	article description	quantity
1	BY 717 212 012	oil reservoir	1
2	BH 812 345 350	o-ring 34,52 x 3,53 mm viton	1
3	MPA 01 073 890	adaptor Ø 20mm - 1/2"	1
4	BT 670 117 290	hose clamp 17x29mm	4
5	BH 812 180 300	o-ring Ø 18 x 3 mm viton	1
6	BH 509 251 009	male stud coupling 10lx1/2" hole 10	1
7	BS 502 000 600	self locking nut m6 din 985	4
8	BS 531 000 600	washer m6 din 125	4
9	BH 720 704 112	filler cap	1
10	BB 321 020 512	key 2x5x12.65 din 6888	1
11	BH 512 671 006	standpipe adaptor 10sr3/8"	1
12	BH 563 000 100	manometer coupler 10lxm16x2	1
13	BH 551 040 490	flexible hydraulic hose 1/4"x490	1
14	MPA 01 074 150	hydraulic pipe (pump return)	1
15	BB 011 000 080	starlock 8mm	1
16	BR 111 080 300	nylon bushing (8,2/16x3)	1
17	BR 112 081 300	nylon bushing with collar (8/11/16x13/2)	1
18	MPA 01 073 850	link rod traction control	1
19	BA 230 010 800	ball joint m8	1
20	BH 509 211 006	male stud coupling 10lx3/8"	8
21	BS 502 000 800	self locking nut m8 din 985	3
22	BS 531 000 800	washer m8 din 125	9
23	BH 400 401 210	hydraulic valve sd5-2	1
23	BH 400 401 210	DISTRIBUTORE CPL SUPERPROF 2015	1
24	BS 554 100 844	bolt m8x60 din603	3
25	BS 512 000 625	bolt m6x25 din 933	4
26	BH 210 103 200	hydraulic pump 3.2cc	1
27	BH 551 040 800	flexible hydraulic hose 1/4"x800	1
28	BH 551 040 871	flexible hydraulic hose 1/4"x870	1
29	BS 511 000 640	bolt m6x40 din 931	1
30	BH 331 204 001	hydraulic engine mm f s 40 c - II	1
31	BH 711 020 010	pipe clamp b-10mm ass.	1
32	BT 134 280 608	messaging 3/8x1/2	1
33	BT 136 260 820	insert connector for hose 20x1/2	1
34	BR 220 619 045	flexible suction pipe Ø19x450mm	1
35	MPA 01 074 170	hydraulic pipe st 2	1
36	MPA 01 074 160	hydraulic pipe st 1	1
37	BS 501 000 700	nut m7 din 934	1
38	BS 512 000 820	bolt m8x20 din 933	4
39	BH 280 612 120	support hydraulic filter 3/4"	1
40	BH 512 611 004	standpipe adaptor 10lx1/4"	1
41	BH 430 110 400	flow control valve 1/4"	1
42	BH 509 211 004	male stud coupling 10lx1/4"	1
43	BS 502 001 200	self locking nut m12 din 985	4
44	BH 331 510 000	hydraulic engine mr n 100 cd	2
45	BS 512 001 235	bolt m12x35 din 933	4
46	BA 281 504 501	hub rear wheel m12x1.5	2
47	BS 535 301 210	lock cup washer m12 din 74361	8
48	BS 512 301 225	bolt m12x1.5x25 din 961	8
49	BS 534 000 800	lock washer m8 din 6798a	2

50	BS 532 008 356	washer m8x35x3	2
51	BB 351 080 732	key 8x7x32 din 6885a	2
52	BH 514 100 804	reduction stud (m-f) 1/2"-1/4"	4
53	BH 513 111 004	banjo 10lx1/4"	4
54	MPA 01 073 960	hydraulic pipe st 3	2
55	BH 510 011 000	equal tee 10l	2
56	MPA 01 073 950	hydraulic pipe st 4	2
57	BH 280 212 000	oil filter (return)	1
58	BT 136 261 219	adaptor Ø 19mm - 3/4"	2
59	BR 220 619 018	flexible suction pipe Ø19x18cm	1
60	BH 518 500 400	blanking plug 1/4"	1
61	BH 802 012 250	o-ring Ø 12 x 2,5 mm	1
62	MPA 01 073 230	support oil reservoir	1
63	BS 512 000 816	bolt m8x16 din 933	4
64	BS 533 000 800	lock washer m8 din 127b	6